

HRTR 46B

Reference scanner

en 02-2014/06 50117040-01



Dimensioned drawing

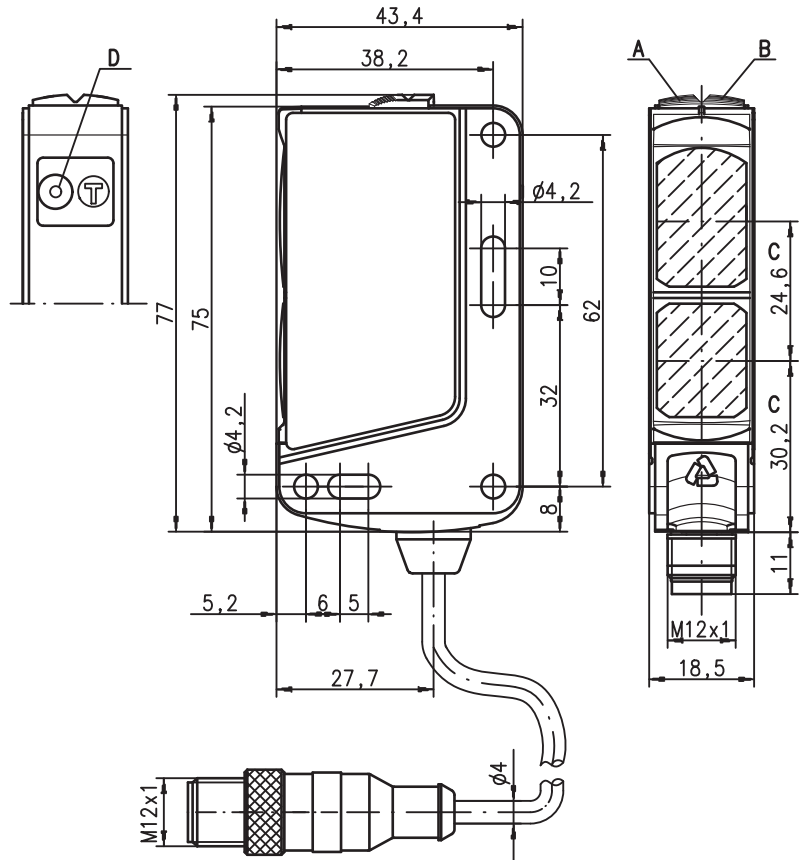

- A** Green indicator diode
- B** Yellow indicator diode
- C** Optical axis
- D** Teach button



200 ... 500mm
Distance on background/reference



- Robust object detection in front of a background
- Reproducible adjustment via teach-in in different teach variants
- Robust behavior through innovative ASIC technology
- IO-Link interface for comprehensive configuration and diagnostic functions
- Remote teach via cable
- Button locking
- Fast alignment through *brightVision*®

Electrical connection

Connector, 4-pin

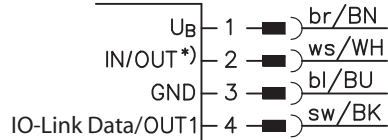

Selection pin 2

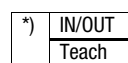

Additional functions configurable via IO-Link



Accessories:

(available separately)

- Mounting systems (BT 46, BTU 300...)
- M12 connectors (KD ...)
- Ready-made cables (K-D ...)
- IO-Link Master SET MD12-US2-IOL1+Zub

We reserve the right to make changes • DS_HRTR46Bref_en_50117040_01.fm

Specifications

Optical data

Minimum height of detection objects	> 10 % of the distance between sensor and reference ¹⁾
Distance on fixed background/reference ²⁾	200 ... 500mm
Light source	LED (modulated light)
Wavelength	620nm (visible red light)

Sensor operating modes

IO-Link	COM2 (38.1kBAud), Frame 2.5, Vers. 1.0
SIO	is supported

Timing

Switching frequency	100Hz ³⁾
Response time	5ms ¹⁾
Delay before start-up	≤ 100ms

Electrical data

Operating voltage U_B ⁴⁾	10 ... 30VDC, for COM2: 18 ... 30V (incl. residual ripple)
Residual ripple	≤ 15 % of U_B
Open-circuit current	≤ 25 mA at 24V ⁵⁾
Switching output	pin 2: teach input (in SIO mode, factory setting), during configuration as switching output: PNP pin 4: IO-Link data, in SIO push-pull mode ⁶⁾
Signal voltage high/low	≥ ($U_B - 2V$) / ≤ 2V
Output current	max. 100mA

Indicators

Green LED in continuous light	ready
Yellow LED in continuous light	object detected
Green and yellow LED flashing at 9Hz	teaching error ⁷⁾

Mechanical data

Housing	plastic
Optics cover	plastic
Weight	50g (with connector) / 65g (with cable and conn.)
Connection type	M12 connector

Environmental data



Ambient temp. (operation/storage)	-40°C ... +60°C / -40°C ... +70°C
Protective circuit ⁸⁾	2, 3
VDE safety class ⁹⁾	II, all-insulated
Protection class	IP 67
Light source	free group (in acc. with EN 62471)
Standards applied	IEC 60947-5-2
Certifications	UL 508, C22.2 No.14-13 ⁴⁾ ¹⁰⁾

Options

Teach-in, line teach, teach button lock,
Activation input **activ** via IO-Link,
Time functions configurable via IO-Link,

- 1) Detection reliability depends heavily on the nature of the objects being detected, the homogeneity of the reference and the sensitivity adjustment of the sensor. Objects on highly heterogeneous bands, partially transparent objects or objects with strongly colored structures should be placed higher.
- 2) Maximum range specified for a background with at least 6 % diffuse reflection
- 3) Response time 7.2 ms (approx. 70Hz) in the IO-Link communication mode
- 4) For UL applications: for use in class 2 circuits only
- 5) ≤ 45mA at 10V
- 6) The push-pull switching outputs must not be connected in parallel.
- 7) Teaching errors can occur if the reference diffuse reflection is too low or when the distance to the reference is outside of the specification.
- 8) 2=polarity reversal protection, 3=short-circuit protection for all outputs
- 9) Rating voltage 50V
- 10) These proximity switches shall be used with UL Listed Cable assemblies rated 30V, 0.5A min, in the field installation, or equivalent (categories: CYJV/CYJV7 or PVVA/PVVA7)

Operate in accordance with intended use!

-  This product is not a safety sensor and is not intended as personnel protection.
-  The product may only be put into operation by competent persons.
-  Only use the product in accordance with the intended use.

Order guide

The sensors listed here are preferred types; current information at www.leuze.com.

	Designation	Part no.
With M12 connector		
Pin 4 push-pull switching output, IO-Link interface	HRTR 46B/L.221-S12	50114036
Pin 2 teach input		

Remarks

- **Mode of operation:**
The reference scanner is only suitable for applications in which objects are to be detected in front of a background with a constant distance to the sensor. It uses the background as a fixed reference much like a retro-reflective photoelectric sensor. Whenever the scanner no longer detects the reference (e.g. a conveying belt or another stable background), an object is signaled on the output. The scanner is particularly well suited for the robust detection of very dark, glossy or partly transparent objects in applications in which a reflector cannot be used.
- **Setting notice:**
The reference scanner should be mounted within the permitted operating range with the smallest possible distance to the background. There is no minimum distance to the objects to be detected. With glossy backgrounds, the scanner must be mounted so that direct reflections from the background surface do not enter the receiver optics. Direct reflections from the reference can have very negative effects on the detection properties. Direct reflections from the detection object are non-critical. The teach-in of the reference scanner is performed without an object on the reference. When doing so, different sensitivity levels can be selected.
- **Entry direction:**
The reference scanner should be mounted so that the objects to be detected approach the sensor from the side. Moving objects in from the connector side or the indicator diode side should be avoided.

IO-Link process data

Output data device

Data bit								Assignment	Meaning
7	6	5	4	3	2	1	0		
								Switching output	0 = inactive, 1 = active
								Reserved	0
								Reserved	0
								Sensor operation ¹⁾	0 = off, 1 = on
								Not assigned	free
								Not assigned	free
								Not assigned	free
								Not assigned	free

1) Sensor operation off when detection is not possible (e.g during the teach event)

Input data device

Data bit								Assignment	Meaning
7	6	5	4	3	2	1	0		
								Deactivation	0 = transmitter active, 1 = transmitter inactive
								Not assigned	free
								Not assigned	free
								Not assigned	free
								Not assigned	free
								Not assigned	free
								Not assigned	free
								Not assigned	free

IO-Link service data

The sensors which feature an IO-Link interface can be configured and diagnosed via the service data.

Parameters

Enabling/locking teach button:

Manipulation protection can be activated with this parameter.

Teach settings for operating levels 1 and 2:

Setting for the 2 teach operating levels which can be activated via the teach button or the teach input can be performed here. When doing so, one of five possible teach sensitivities can be assigned to each operating level. A teach-in can be triggered via the button, via an IO-Link command or via the teach input in SIO-mode.

Functions of pins 2 and 4:

The following functions can be configured for SIO operation for the inputs/outputs on pin 2 and/or pin 4:

- Switching outputs
- Activation input
- Teach input

Time module:

All normal time functions can be configured in a range of 10ms ... 25s via the time module. The activated time function is effective for both switching outputs.

Setting factory settings:

The factory settings of the sensor can be restored via the "**Restore Factory Settings**" system command.

Diagnostics (observation)

Reading out of the object distance:

The distance to the object, which is currently located in the light beam, can be measured via the **Measure Distance** system command. The sensor function is not in operation during the measurement process. The result can be read out via the "**Distance**" parameter.

Detailed information about the IO-Link service data and the IODD can be found at www.leuze.com.

Teach process

The teach-in of the reference scanner is performed without an object on the free reference (fixed background). When doing so, two different sensitivity levels can be selected via the two operating levels. The sensitivity level is selected depending on the homogeneity of the reference. 5 sensitivity levels can be assigned arbitrarily to the operating levels via the IO-Link interface. The higher the chosen sensitivity of the sensor, the more reliable object detection is, but at the same time it is more likely for an inhomogeneity on the reference to be signaled as an object. If it is not clear which sensitivity level should be selected, a low sensitivity level should be chosen. If the object cannot be detected reliably, the sensitivity can be increased. After a new sensitivity level has been selected via IO-Link, a new teach event must be performed so that the new setting goes into effect.

Available sensitivity levels

- "very robust"** This sensitivity level is suitable for very non-homogeneous references, such as colorful link conveyors with rolls and very glossy elements or conveyors on which large water drops can accumulate.
- "robust"** This sensitivity level is assigned in the **factory settings of operating level 1** and is suitable for non-homogeneous references such as link conveyors with rolls or plastic conveyors with glossy elements.
- "standard sensitivity"** This sensitivity level is assigned in the **factory settings of operating level 2** and is suitable for homogeneous conveyors or non-glossy dimple tape conveyors.
- "high sensitivity"** This setting should only be used for fixed references such as part of the machine base. This setting is not suitable for conveyors.
- "very high sensitivity"** This setting should only be used for fixed, diffuse references such as a part of the machine base for which a big change, e.g. due to soiling or fogging, is not expected.

Application example: detection of can containers on a link conveyor

In this application, the sensor is installed perpendicular to the conveyor. To ensure robust detection, the sensor should be mounted within the scanning range and as close to the band as possible (e.g. 300mm for can containers). There is no minimum distance to the container.

The sensor is assembled horizontally to the transport direction, i.e. the containers only run laterally under the sensor from the left or the right. Moving objects in from the connector side or the indicator diode side should be avoided. A maximum sensor tilt angle of 20° towards or away from the transport direction is permissible to bridge gaps between the containers.

For glossy link conveyors, the sensor must point at the band with an angle of 5° ... 15°. It is recommendable to tilt the connector downwards.

Optimal detection of different can containers is achieved when the sensor is aligned so that the light spot runs through the center of a line of cans in the container and not over the gap between the cans in the container.

Since the background of a link conveyor is generally non-homogeneous, the **"robust"** teach process should be used in operating level 1. Teach-in is executed directly on the stopped conveyor.

Operation via teach button

Teach in operating level 1 (factory setting: "robust")

- Press teach button until both LEDs flash simultaneously.
- Release teach button.
- Ready.



2 ... 7s



simultaneously
flashing at
3Hz

HRTR 46B

Reference scanner

Teach in operating level 2 (factory setting: "standard sensitivity")

- Press teach button until both LEDs flash alternately.
- Release teach button.
- Ready.



7 ... 12s



alternately
flashing at
3Hz

Adjusting the switching behavior of the switching output – light/dark switching

This function permits inversion of the sensors' switching logic.

- Press the teach button until only the green LED flashes. The yellow LED then shows the inverted switching logic:
 - ON = switching outputs light switching (in the case of complementary sensors, Q1 (pin 4) light switching, Q2 (pin 2) dark switching), this means output active when object is detected.
 - OFF = switching outputs dark switching (in the case of complementary sensors, Q1 (pin 4) dark switching, Q2 (pin 2) light switching), this means output inactive when object is detected.



> 12s

LED yellow

ON = light switching

OFF = dark switching



LED green
flashes with
3Hz



- Release teach button.
- Ready.

Setting factory settings

It's possible to restore the factory settings of the sensor via the teach button.

- Continue to press the teach button during power-on. The green and the yellow LEDs flash synchronously
- Continue to press the teach button until green and yellow LEDs flash synchronously.
- Release teach button.

The factory settings of the sensor have been restored.



7 ... 10s



simultaneously
flashing for 7s
with 3Hz



alternately
flashing at
3Hz

Sensor adjustment (teach) via teach input (pin 2)



The following description applies to PNP switching logic!

Signal level LOW $\leq 2V$

Signal level HIGH $\geq (U_B - 2V)$

Line teach operating level 1

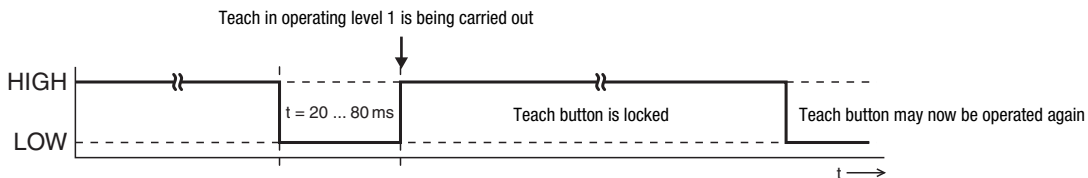

Line teach operating level 2

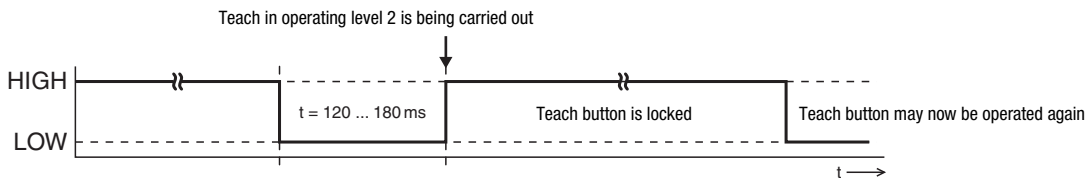

Light switching logic

Switching outputs light switching, this means outputs active when object is detected. In the case of complementary switching outputs, Q1 (pin 4) light switching, Q2 (pin 2) dark switching.

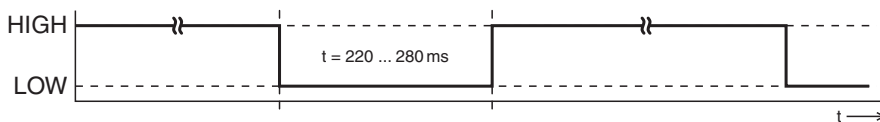

Dark switching logic

Switching outputs dark switching, this means outputs inactive when object is detected. In the case of complementary switching outputs, Q1 (pin 4) dark switching, Q2 (pin 2) light switching.

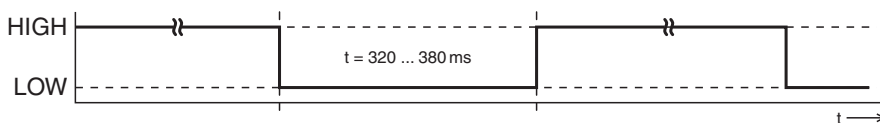

Locking the teach button via teach input (Pin 2)



A **static HIGH signal** ($\geq 20\text{ms}$) at the teach input locks the teach button on the sensor, if required, so that no manual operation is possible (e.g., protection from erroneous operation or manipulation).

If the teach input is not connected or if there is a static low signal, the button is unlocked and can be operated freely.

